



oSg Eagle Door

Problem : High Prices

Solution : oSg Eagle Door

The best value in the market!

Solution : oSg



- Available in 18 and 20 ga Cold Rolled and Galvanized Steel
- Honeycomb and Polystyrene cores
- Flush and 6 panel
- Square edge non-handed design minimizes inventory
- Inverted 16 ga bottom channel allows for modification to meet floor conditions
- Mechanically interlocking edge provides strength and easy modifications
- 16 ga Flush top channel
- 12ga Closer reinforcement bonded to each skin
- Available in Cylindrical prep (161), Mortise prep (86)
- 3 hr Warnock Hersey fire rating ; Listed for fire door installations requiring positive or negative pressure testing (UBC-7-2-97, UL 10B, and UL 10C), up to 3070 pairs

Corrosion Resistance

- Doors are chemically treated to insure paint adhesion
- Doors are coated with a baked-on, double layer epoxy rust inhibitive primer
- All products meet or exceed ANSI A250.1-1998
- Salt Spray resistance: Acceptance Criteria for Prime Painted Steel Doors and Frames

Standards & Codes

- Meets or exceeds ANSI/SDI A250.6 – 2003 “Recommended Practice for Hardware Reinforcing on Standard Steel Doors and Frames”
- Locations are in accordance with ANSI/DHI A115
- Meets the requirements of ANSI A250.8-2003 (Commonly known as SDI-100)

Doors must be purchased in 5 pallet (100 door) minimum; orders may include a mix of styles however each style must be ordered in 20 door increments



opening Solutions group

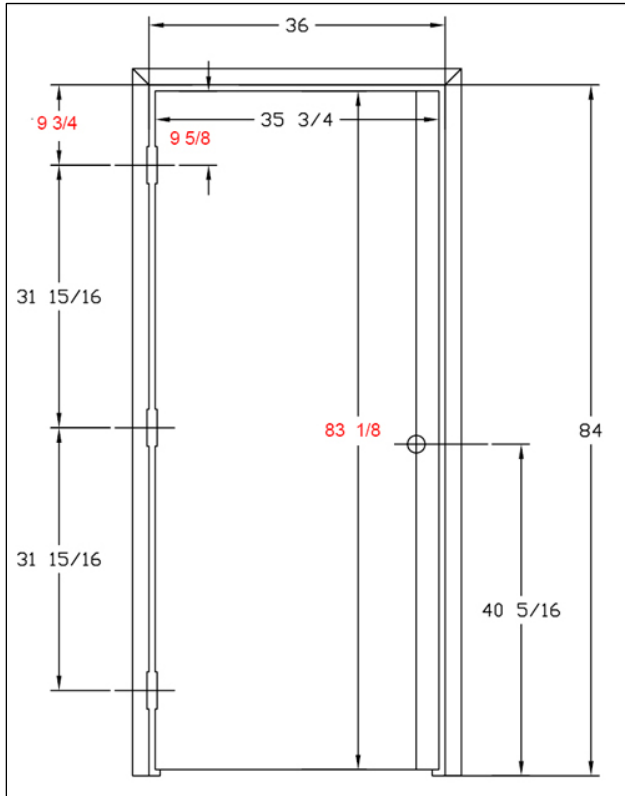

3070 Door with Frame (standard hinge locations)

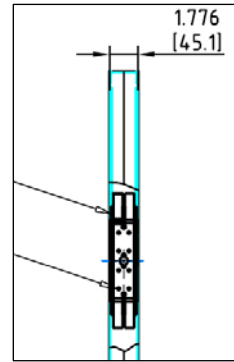

10 ga Hinge reinforcement

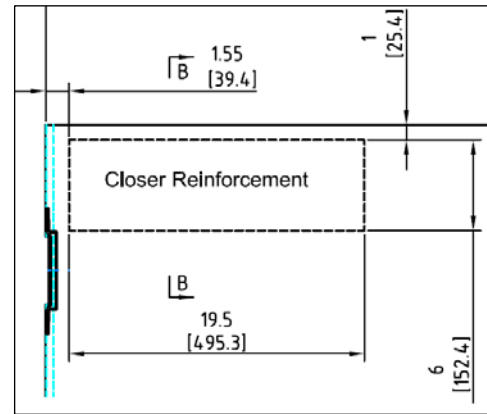

Closer reinforcement location

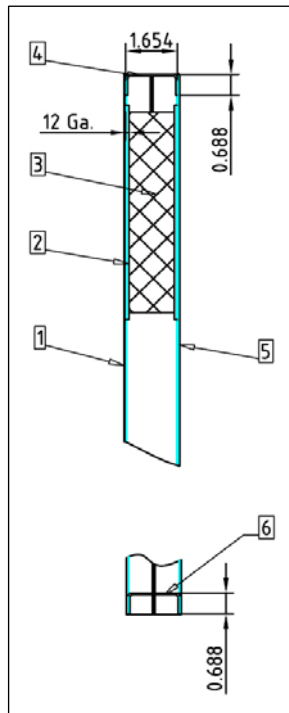

1. 18ga Steel
2. 12ga closer reinforcement (standard)
3. Honeycomb core filler between closer reinforcement plates
4. 16ga Top flush cap
5. 2 component epoxy prime paint
6. 16ga inverted bottom channel

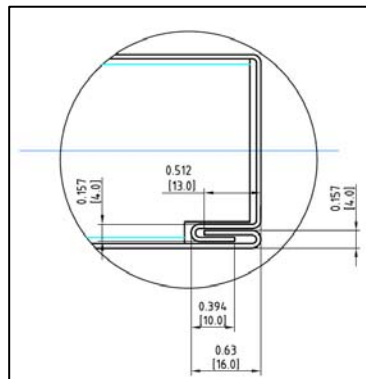

Mechanical Edge

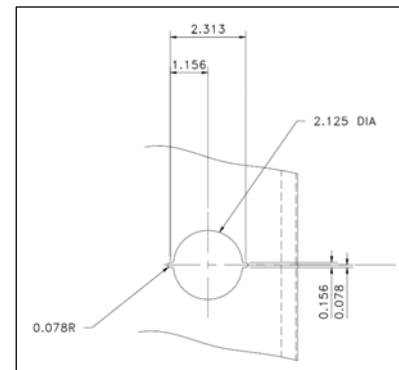

Cylindrical Lock (161)